

# Output ripple analysis of solar powered PWM Z-Source DC-DC converter

<sup>1</sup>Ms.LAKSHMLK.S, <sup>2</sup>Mr.K.SEKAR

1. PG Scholar, Hindusthan College of Engineering and Technology, Coimbatore.

[Lakshmisanan705@gmail.com](mailto:Lakshmisanan705@gmail.com)

2. Assistant Professor (EEE), Hindusthan College of Engineering and Technology, Coimbatore.

**Abstract-** Maximum power point trackers (MPPTs) play a crucial role in photovoltaic (PV) system. They increase the efficiency of the solar photovoltaic system by increasing the output power. MPPT algorithms are vital in photovoltaic systems because these arrays have a non linear voltage-current characteristic with a unique point where the power produced is maximum. The power output from the solar panel mainly depends upon various factors like solar irradiance, temperature and so on. To harvest the maximum power output from the solar panel, it is necessary to operate the photovoltaic (PV) system at the maximum power point (MPP). This paper presents the Matlab/Simulink arrangement of perturb & observe (P&O), a classification of MPPT algorithm which is responsible for driving the dc-dc boost converter to track maximum power point (MPP). This paper also presents the theoretical analysis of z-source converter which helps to overcome the disadvantages of traditional current and voltage source converters.

## 1. INTRODUCTION

Energy is the prime mover of economic growth and is vital to the sustenance of a modern economy. Future economic growth mainly depends on the long-term availability of energy from sources that are affordable, accessible and environmentally harmless. Government, industry and independent studies have shown that cost-effective energy efficiency improvements could reduce electricity use by 25% to 75% of total national use within 10-20 years without affecting quality of life or manufacturing output. According

to the analyses India is world's 6th largest electrical energy consumer and accounting 3.4% of global energy consumption. In the current situation installed power generation capacity of India stands at 1, 85,496.62MW as on 31.11.2011. About 64% of the electricity consumed in India is generated by thermal power plants and 20.87% by hydroelectric power plants and 2.56% by nuclear power plants and 11.21% from renewable energy sources. According to studies conducted by the International Energy Agency, solar power generators can produce most of the world's electricity within next 50 years, and thereby reducing the emissions of greenhouse gases that harm the environment. Photovoltaic and solar-thermal power plants may meet most of the world's demand for electricity by 2060 and half of all energy needs with wind, hydropower and biomass plants supplying major part of the remaining generation.

Photovoltaic and concentrated solar power together can become the major source of electricity. Our country receives solar energy equivalent to over 5,000 trillion kWh per year. The daily average solar energy incident over India varies

from 4 -7 kWh per square meter per day depending upon the location and environment factors. Solar photovoltaic (PV) energy is nowadays one of the most important available resources because is free, abundant, affordable and pollution-free and distributed all over the world. But unfortunately, PV generation systems have two major problems: the conversion efficiency of electric power generation is low (in general less than 16%, especially under low irradiation conditions), and the amount of electric power generated by solar arrays changes continuously with atmospheric conditions. Moreover, the solar cell V-I characteristic is nonlinear and varies with irradiation and temperature. In general, there is a unique point on the V-I or V-P curve, called the Maximum Power Point (MPP), at which the entire PV system (array, converter, etc.,) operates with maximum efficiency and produces its maximum power output. The location of the MPP is not known, but can be located, either through calculation models or by searching algorithms. Therefore Maximum Power Point Tracking (MPPT) techniques are needed to maintain the PV array's operating point at its MPP. The P&O, incremental conductance (INC) method are the most known methods of searching algorithms[9]-[14] to track the MPP by updating repeatedly the operating voltage of the PV array varying the duty cycle of the power converter with a fixed step size. Even though the solar energy is present throughout the day but the solar irradiation levels vary continuously due to sun intensity on the solar panel varies continuous due to the variation in direct and diffused radiation falling on the solar panel and also because of the unpredictable shadows made by clouds, birds, trees, etc.

The common inherent drawback of renewable systems like wind and photovoltaic systems are their intermittent natures that make them unreliable. However, by incorporating maximum power point tracking (MPPT) algorithms, the photovoltaic system's power transfer efficiency and reliability can be improved significantly as it can continuously maintain the operating point of the solar panel at the MPP pertaining to that irradiation and temperature and so on as shown in Fig.1. Figure shows the power voltage characteristics of photovoltaic module at different voltage levels. The output power of a PV cell is a non linear function of the operating voltage and this function has a maximum power point (MPP) corresponding to a particular value of voltage. In order to operate the panel at the MPP, an energy power converter must be connected at the output of a PV array, such converter forces the output voltage of the PV array is equal to the optimal value, also taking into account the atmospheric condition.

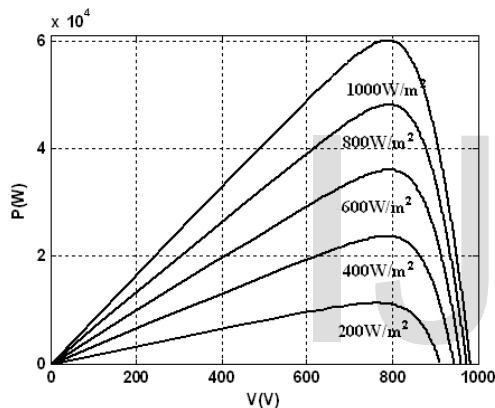

Fig.1 Power-voltage characteristics of photovoltaic module at different irradiance levels

A DC-to-DC converter is an electronic circuit which converts a source of direct current (DC) from one voltage level to another. It is a class of power converter. There are different types of converters based upon their output voltage level and the sources of inputs used. The basic types of converters based upon their output voltages are

- Boost converters
- Buck converters
- Buck-Boost converters
- CUK converters
- SEPIC converters

Switch Mode Power Supply [6] topologies follow a set of rules. A very large number of converters have been proposed in [1]-[5], which however can be seen to be minor variations of a group of basic DC-DC converters – built on a

set of rules. Many consider the basic group to consist of the three: BUCK, BOOST and BUCK-BOOST converters. The CUK, essentially a BOOST-BUCK converter, may not be considered as basic converter along with its variations: the SEPIC and the zeta converters.

Among these converters the converter type which is used for the purpose of the proposed model is Boost type converter. The boost converter [15] converts an input voltage to a higher output voltage. The boost converter is also called a step-up converter. Boost converters are used in battery powered devices, where the electronic circuit requires a higher operating voltage than the battery can supply, e.g. notebooks, mobile phones and camera-flashes. Features of a boost converter are, Continuous input current, eliminates input filter. Pulsed output current increases output voltage ripple. Output voltage is always greater than input voltage. Features of a buck - boost converter are Pulsed input current, requires input filter. Pulsed output current increases output voltage ripple, Output voltage can be either greater or smaller than input voltage. The single-ended primary-inductance converter (SEPIC) is a DC/DC-converter topology that provides a positive regulated output voltage from an input voltage that varies from above to below the output voltage. This type of conversion is handy when the designer uses voltages from an unregulated input power supply such as a low-cost wall wart. Unfortunately, the SEPIC topology is difficult to understand and requires two inductors, making the power-supply footprint quite large. So the boost converters are used here for the experimental purpose. But the main problems concerned with these converters are the ripples present in their output voltage waveform. In this paper a new method is introduced to reduce the ripple contents present in a renewable energy powered DC-DC converters.

## 2. PHOTOVOLTAIC MODULE

A general simulation model of photovoltaic cells is adopted proposed by [3] in this paper. The typical model of a solar cell is shown in fig. 2

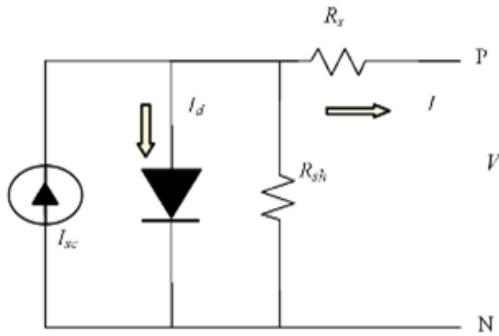

Fig.2. Equivalent circuit of PV cell

$$I_c = I_{ph} - I_o \left\{ \exp \left[ \frac{q(V + RI)}{AKT} \right] - 1 \right\} - (V + IR) / R_{sh}$$

$I_{ph}$  : Photo current

$I_c$  : Output current

$R_{SH}$  : Parallel resistance

$V$  : Output voltage

A Single diode model based PV module considering constant insulation and temperature is developed in Simulink. This module is used as a source for the maximum power point tracker system. The proposed solar panel has been modelled and simulated using the MATLAB/Simulink as shown in Fig.3. As the radiation and temperature is kept constant, the output voltage, current is constant as shown in Fig.4. As per the details given in [ ] the output of a PV panel under constant radiation is shown in Fig.4. The output voltage remains as constant. In the proposed model simulation the input is a ramp signal and the radiation is constantly increasing.

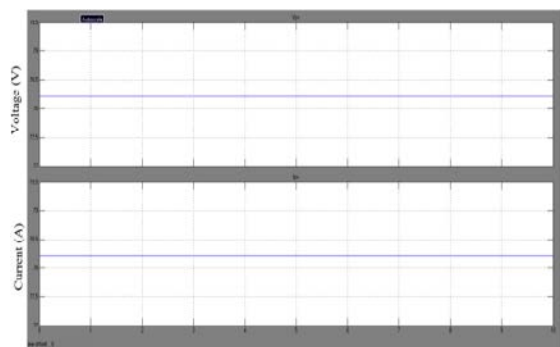

Fig.3.voltage current output under constant radiation

During the start of the system, the controller varies the duty cycle 'α' to increase the power output, when the MPP is reached, the controller maintains a constant duty cycle which can be evidenced in the PWM signal generated by the controller. As constant radiation and temperature are not practically possible due to natural changes in weather, a

solar cell or PV model with varying insulation and temperature were also designed

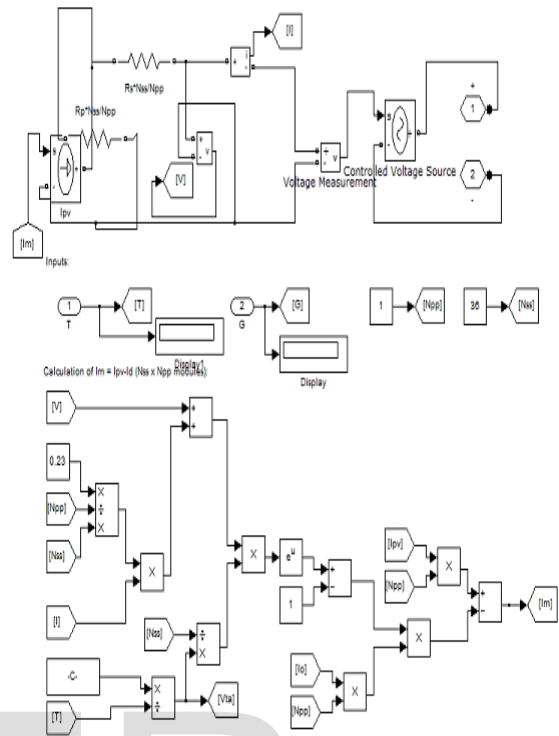

Fig.4. Simulation model of a PV panel using MATLAB/Simulink

The variation in the inputs such as radiation and temperature are applied using repeating sequence stair. On the basis of this model, the output characteristics of PV are simulated and shown in Fig.4, using MATLAB/Simulink. The radiation change affects the photon generated current and has very little effect on the open circuit voltage. Whereas the temperature variation affects the open circuit voltage and the short circuit current varies very marginally.

## 2.1 MAXIMUM POWER POINT TRACKING

A typical solar panel converts only 30 to 40 percent of the incident solar irradiation into electrical energy. Maximum power point tracking technique is used to improve the efficiency of the solar panel. According to Maximum Power Transfer theorem, the output power of a circuit is maximum when the source impedance matches with the load impedance. In the source side a boost converter is connected to a solar panel in order to enhance the output voltage. By changing the duty cycle of the boost converter appropriately the source impedance is matched with that of the load impedance. Several approaches have been proposed for tracking the MPP. Among those methods, the Perturb and observe (P&O) and incremental conductance (INC) methods are widely used although they have some problems such as the oscillation around MPP and

confusion by rapidly changing atmospheric conditions. In general, these tracking approaches use a fixed iteration step size, which is determined by the accuracy and tracking speed requirement.

### 3. Z-SOURCE CONVERTERS

The impedance-source or Z-source converter was proposed in 2002 [1]. The salient feature of the PWM Z-source converter is that, when it is operated in the inverter mode, it has the unique feature of being a voltage buck-boost inverter as opposed to either being a buck or a boost inverter. This was a significant step in the field of dc-ac power conversion and the topic was given due attention by researchers in academia and the industry [2]–[6]. Majority of the literature corresponding to PWM Z-source converter focuses on the inverter mode of operation or the PWM Z-source inverter. This paper specifically deals with the dc-dc converter mode of operation of the PWM Z-source converter. A quasi-Z-source based isolated dc/dc converter is presented in [5]. Quasi-Z-source based dc-dc converter [3] utilizes altered impedance or Z-network derived from the impedance network utilized in the original Z-source inverter of [1]. The authors in [7] and [8] present a brief analysis of a loss-less Z-source dc-dc converter aided by simulation results. The authors in [4] explore the double input version of the PWM Z-source dc-dc converter. The authors in [3] present a brief analysis of a loss-less Z-source dc-dc converter in discontinuous conduction mode and the simulation results.

The motivation of this paper is to explore the steady-state operation of PWM Z-source converter in a more elaborate manner, and to present output voltage ripple analysis of the PWM Z-source dc-dc converter, which has not been reported yet. Additionally, there has been a renewed interest in isolated and non-isolated voltage step-up PWM dc-dc converters for renewable energy and distributed power generation systems. Typically, the low output voltage energy source, like fuel-cells requires a PWM dc-dc converter to (1) provide a voltage boost and (2) act as a protective buffer between the load and the energy source. Compared to the conventional boost converter, the PWM Z-source dc-dc converter has a higher input-to-output dc voltage boost factor for the same duty ratio, isolates the source and the load in case of a short-circuit at the load side, and has a second-order output filter. This makes PWM Z-source dc-dc converter a potential topology candidate for renewable energy applications. These features prompt the necessity for a detailed investigation of the steady-state behaviour of the PWM Z-source dc-dc converter in CCM. The PWM Z-source dc-dc converter is a boost converter. The PWM Z-source dc-dc converter shown in Fig. 2 consists of a

diode two identical inductors denoted by and two identical capacitors denoted by connected in a manner to obtain the unique impedance or Z-network, an active switch such as a MOSFET, a second order low-pass filter

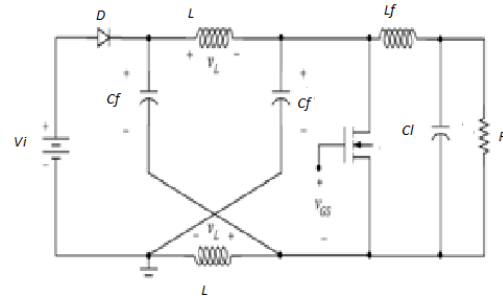

Fig.5. Circuit diagram of z-source converter

The expression for determining the duty cycle for minimum voltage is

$$D = 1 - \frac{V_{IN(MIN)} \times \eta}{V_{OUT}} \quad - (1)$$

$V_{IN}$  = Minimum input voltage  
 $V_{OUT}$  = Desired output voltage  
 $\eta$  = Efficiency of converter

Often data sheets give a range of recommended inductor values. If this is the case, it is recommended to choose an inductor from this range. The higher the inductor value, the higher is the maximum output current because of the reduced ripple current. The lower the inductor value, the smaller is the solution size. Note that the inductor must always have a higher current rating than the maximum current because the current increases with decreasing inductance.

$$L = \frac{V_{IN} \times (V_{OUT} - V_{IN})}{\Delta I_L \times f_s \times V_{OUT}} \quad - (2)$$

The minimum value for the input capacitor is normally given in the data sheet. This minimum value is necessary to stabilize the input voltage due to the peak current requirement of a switching power supply. The best practice is to use low equivalent series resistance (ESR) ceramic capacitors. The dielectric material should be X5R or better. Otherwise, the capacitor can lose much of its capacitance due to DC bias or temperature. With external compensation, the following equations can be used to adjust the output capacitor values for a desired output voltage ripple.

$$C_{OUT(MIN)} = \frac{I_{OUT(MAX)} \times D}{f_s \times \Delta V_{OUT}} \quad - (3)$$

$$f_s = \text{Minimum switching frequency}$$

#### 4. PROPOSED METHOD TO REDUCE RIPPLE

The proposed method makes use of renewable energy as power source. The type of input source used here is impedance source (Z-SOURCE). These types of converters are helpful in overcoming the demerits of traditional current and voltage source converters. The salient feature of the PWM Z-source converter is that, when it is operated in the inverter mode, it has the unique feature of being a voltage buck-boost inverter as opposed to either being a buck or a boost inverter. This was a significant step in the field of dc-ac power conversion. The impedance-source power converter (Z-Source) is a new electronic circuit recently recognized because of its applications in power conversion and power electronics.

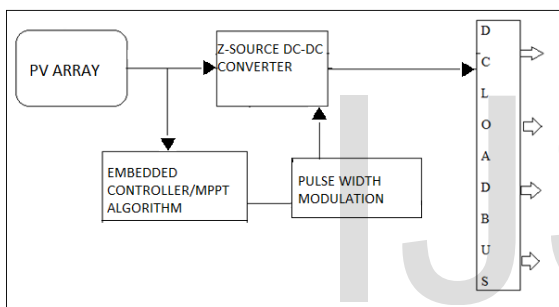

Fig.6. Block diagram of proposed model

The Z-Source found to be more efficient than other commonly used power converters. For example, voltage buck-boost capability needed in dc-to-ac fuel cell and renewable energy applications. Other applications are related to the improvement in the performance of electric drives. The Z-Source can be more reliable than the T-filter when used in utility systems where its large dc inductive current filtering and implicit output short-circuit protection are found to be desirable. Fig.6. shows the simulation diagram of the proposed model using MATLAB/SIMULINK. The output voltage and current of solar panel will be monitored and given to embedded controller. The MPPT algorithm used here is P&O type and it will be used for modulating the pulse width. The power will be conserved here. Since the proposed model uses MOSFET for switching and P&O algorithm for finding MPP the amount of ripple can be reduced effectively.

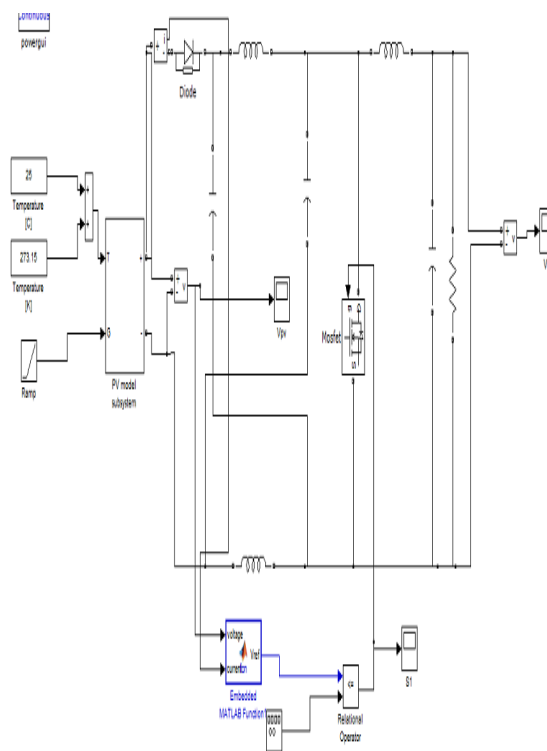

Fig.6. Simulation diagram of proposed model

#### 4.1 PERTURB AND OBSERVE METHOD

The most commonly used MPPT algorithm is the P&O due to its simplicity of implementation. However, it has some drawbacks, like oscillations around the MPP in steady state operation and also slow response speed at the event of changes in solar irradiance .Fig. 5 shows the algorithm of P&O algorithm is based on the calculation of the PV array output power and the power change by sensing both the PV current and voltage. . The controller operates periodically by comparing the present value of the power output with the previous value to determine the change on the solar array voltage or current. The algorithm reads the value of current and voltage at the output solar PV module. Power is calculated from the measured voltage and current. The magnitude of voltage and power at kth instant are stored. Then the magnitude of power and voltage at (k+1)th instant are measured again and power is calculated from the measured values.

If the magnitude of power is increasing, the perturbation will continue in the same direction in the next cycle, otherwise the perturbation direction is reversed. When the MPP is reached, the system then oscillates around the MPP.



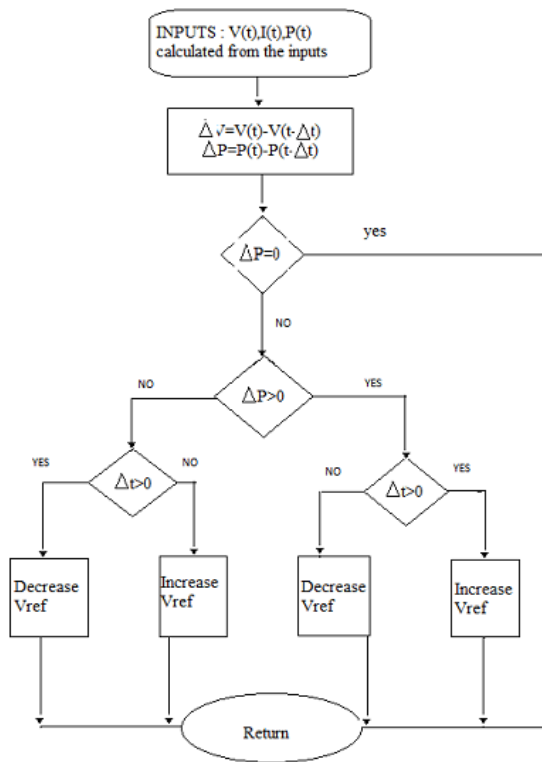

Fig.7.Flow chart of P&O MPPT algorithm



Fig.8. Output of P&O MPPT algorithm

In order to minimize the oscillation, the perturbation step size should be reduced such that when the operating point is away from the MPP, the step change in duty cycle should be large, when it nears the MPP, the step change in 'α' should reduce. The simulation of output of P&O MPPT algorithm at varying irradiance condition is shown in Fig.7.

## 5. RESULTS AND DISCUSSIONS

An example PWM Z-Source DC-DC converter with specifications  $f_s = 40 \text{ kHz}$ ,  $L = 330 \mu\text{H}$ ,  $C = 220 \mu\text{F}$ ,  $R_L = 150 \Omega$ ,  $L_f = 330 \mu\text{H}$ ,  $C_f = 470 \mu\text{F}$  is selected. The capacitors

are electrolytic capacitors. The resistance of diode is  $R_{ON} = 1 \mu\Omega$  with  $V_F = 0.8\text{V}$  and snubber resistance  $R_s = 500 \Omega$ . The FET resistance  $R_{ON} = 0.1 \Omega$  and internal diode resistance  $R_d = 0.01 \Omega$ .

According to the experimental values given in [8] the output voltage waveforms for different inductor values are shown here. From these graphs we can understand that the variations present in the output content is  $\pm 1\text{V}$ .

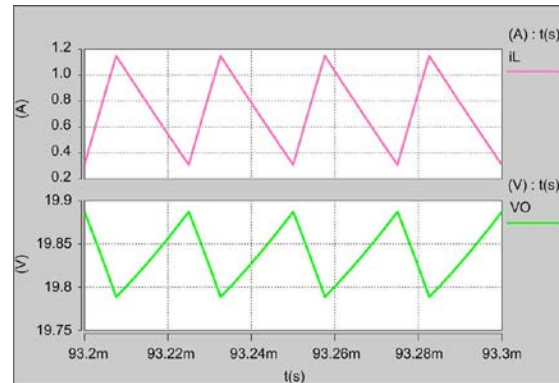

Fig.9.Simulated inductor current and output voltage for  $L = 175 \mu$

In the proposed model the input supply is obtained from a PV panel and it is increasing in nature. The maximum output voltage capacity of solar panel used in the prototype is 16V. The simulated results of prototype are given in the following figure. By observing the output voltage waveform it is clear that the ripple content has been reduced effectively and the variations in the output voltage waveform is  $\pm 0.01$

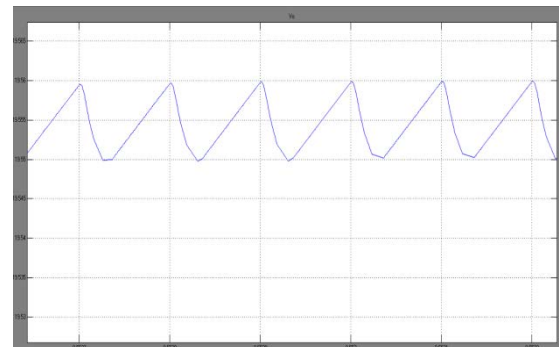

Fig.10.Simulated output voltage for  $L = 175 \mu\text{H}$

## 6. CONCLUSION

An analysis of PWMZ-source dc-dc converter operating in CCM has been presented here. The input power supply is obtained by making use of a solar cell in the input section. The main problem while using a renewable energy source is the ripple contents present in the output waveform. In order to remove these unwanted components present in the output due to the non consistency in solar power and

switching disturbances in converter circuits a combination of z-source converter with MPPT algorithm is used in the proposed model. P&O method of MPPT algorithm is implemented using MATLAB/SIMULINK. The MPPT method simulated in this paper is able to improve the dynamic and steady state performance of the PV system simultaneously. Through simulation it is observed that the system completes the maximum power point tracking successfully despite of fluctuations. When the external environment changes suddenly the system can track the maximum power point quickly. The disadvantage of the PWM Z-source dc-dc converter as compared to conventional boost converter topology is its higher part count. However, the merits of the PWM Z-source dc-dc converter are:

- For the same duty ratio and input voltage, PWM Z-source dc-dc converter offers a higher output voltage.
- Since the diode is turned OFF when the MOSFET is ON, if there is a short on the load side, the source is isolated from the load. This provides inherent immunity to disturbances at the load side. This can be critical if the fuel or energy source is expensive and is to be protected.
- Since the input-to-output voltage conversion factor is  $M_{VDC} = 1 - D/1 - 2D$  for  $D > 0.5$ , the output voltage is inverted. It can be employed, where such a feature is desired

## REFERENCES

[1] F. Z. Peng, "Z-source inverter," *IEEE Trans. Ind. Appl.*, vol. 39, no. 2, pp. 504–510, Mar. 2003

[2] P. C. Loh, D. M. Vilathgamuwa, C. J. Gajanayake, Y. R. Lim, and C.W. Teo, "Transient modeling and analysis of pulse-width modulated Z-source inverter," *IEEE Trans. Power. Electron.*, vol. 22, no. 2, pp. 498–507, Mar. 2007

[3] X. Fang and X. Ji, "Bidirectional power flow Z-source dc-dc converter," in *Proc. IEEE Veh. Power Propulsion Conf. (VPPC'08)*, pp. 1–5.

[4] J. Zhang and J. Ge, "Analysis of Z-source DC-DC converter in discontinuous current mode," in *Proc. IEEE Power Energy Eng. Conf. (APPEEC)*, Asia-Pacific, 2010, pp. 1–4.

[5] D. Vinnikov and I. Roasto, "Quasi-Z-source based isolated DC/DC converters for distributed power generation," *IEEE Trans. Ind. Electron.*, vol. 58, no. 1, pp. 198–201, Jan. 2011.

[6] B. Axelrod, Y. Berkovich, and A. Ioinovici, "Switched-capacitor/ switched-inductor structures for getting transformerless hybrid DC-DC PWM converters," *IEEE Trans. Circuits Syst. I, Reg. Papers*, vol. 55, no. 2, pp. 687–696, Mar. 2008.

[7] A. Shahin, M. Hinaje, J. Martin, S. Pierfederici, S. Rael, and B. Davat, "High voltage ratio DC-DC converter for fuel cell applications," *IEEE Trans. Ind. Electron.*, vol. 57, no. 12, pp. 3944–3955, Dec. 2010.

[8] Veda Prakash Galigekere and Marian K. Kazimierczuk, *Fellow, IEEE*, "Analysis of PWM Z-Source DC-DC Converter in CCM for Steady State", *IEEE Transaction on Circuits and systems—I: Regular papers*, VOL. 59, NO. 4, April 2012

[9] C. Liu, B. Wu and R. Cheung, "Advanced algorithm for MPPT control of photovoltaic systems", *Canadian Solar Buildings Conference Montreal, August 20-24, 2004 Refereed Paper*

[10] Jung-Min Kwon, *Student Member, IEEE*, Eung-Ho Kim, Bong-Hwan Kwon, *Member, IEEE*, and Kwang-Hee Nam, *Member, IEEE*, "High-Efficiency Fuel Cell Power Conditioning System With Input Current Ripple Reduction", *IEEE Transactions on Industrial Electronics*, VOL. 56, NO. 3, March 2009

[11] C.Sree Kumar, Vivek Agarwal, *Member IEEE*, "A hybrid control algorithm for voltage regulation in DC-DC boost converter", *IEEE trans. On Industrial Electronics* vol.55, no.6 June 2008

[12] Miao zhu, Fanglin Luo, *Members IEEE*, "Remaining inductor current phenomenon of complex DC-DC converter in discontinuous current mode: general concept and case study", *IEEE trans. On power electronics*. Vol 23. No.2 March 2008

[13] Daniel Diaz, David menses, *Member IEEE*, Jesus Oliver, "Dynamic analysis of a boost converter with ripple cancellation network by model reduction techniques", *IEEE trans. On power electronics*. Vol.53. no.4 April 2009

[14] Boyu Hu, Lenian huo, "A new modelling method for DC-DC converter based on Verilog A", *proceedings of the international multiconference of engineers and computer scientists 2010*. Vol II IMECS March 2010

[15] Bijan Zahedi, Larn Norum, *Members IEEE*, "Modelling and control of an isolated boost converter for system level studies", *IEEE trans. On power electronics* August 2010